

SIMPLE BIAS CIRCUIT CREATES ALL-OFF STATE FOR HMC436MS8G

Introduction

The HMC436MS8G is a low cost C-band DPDT switch that operates between 4.9 and 5.9 GHz. This switch can operate as an integrated antenna diversity and transmit/receive switch for the 802.11a/HiperLAN and UNII radio platforms. The design provides 20 dB of isolation between antennas and between Tx and Rx ports. The switch features 1-dB insertion loss and high power handling capability. Switch state is controlled using four control voltage lines toggled between 0 and +3 to +5V.

The functional diagram and truth table for the HMC436MS8G are shown in Figure 1 and Table 1 respectively. In the normal operation of this switch, there is always one “on” path and subsequently two of the control lines are high (+3 to +5V) while the others are low (0V). In order for this switch to operate properly, there must be at least one high-level control line to bias the switch properly. Without any high level control lines it would be impossible to pinch off the switch FET’s in the channels the user wants to turn off.

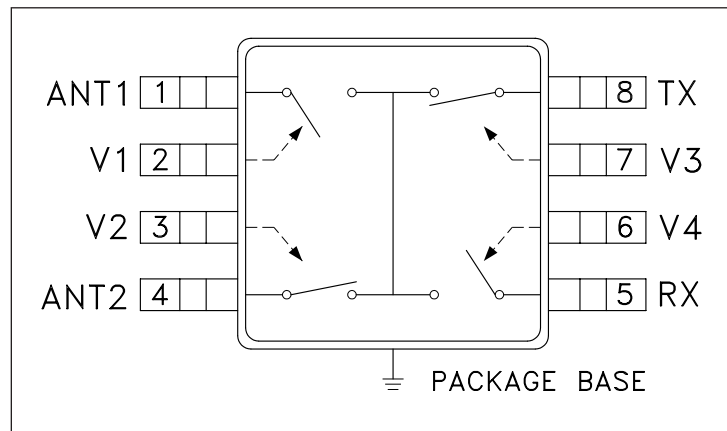

Figure 1 - Functional Diagram

Path	V1	V2	V3	V4	State
ANT1 - Tx	High	Low	High	Low	1
ANT1 - Rx	High	Low	Low	High	2
ANT2 - Tx	Low	High	High	Low	3
ANT@ - Rx	Low	High	Low	High	4

Table 1 - Truth Table

All-Off Application Circuit

Applications requiring an “all-off” state can be implemented with the addition of a simple biasing circuit added at any one of the RF ports. A schematic diagram of this circuit is shown in Figure 2. In this figure, an external bias circuit is added to the ANT1 port that consists of a series inductor and resistor with a bypass capacitor. Due to the small control currents involved (125µA total), this traditional biasing circuit can use a relatively large series resistor. This resistance not only provides additional isolation from the DC circuit, but also minimizes any resonances caused by the biasing circuit. The blocking capacitors, C_b, are selected to minimize insertion loss without introducing any

SIMPLE BIAS CIRCUIT CREATES ALL-OFF STATE FOR HMC436MS8G

resonances into the response. Values of C_b in the range from 2 to 100 pF will yield acceptable results over the 5 – 6 GHz range. With an external bias available, all of the control lines can now be set to their low state resulting in an all-off condition. The modified truth table is shown in Table 2.

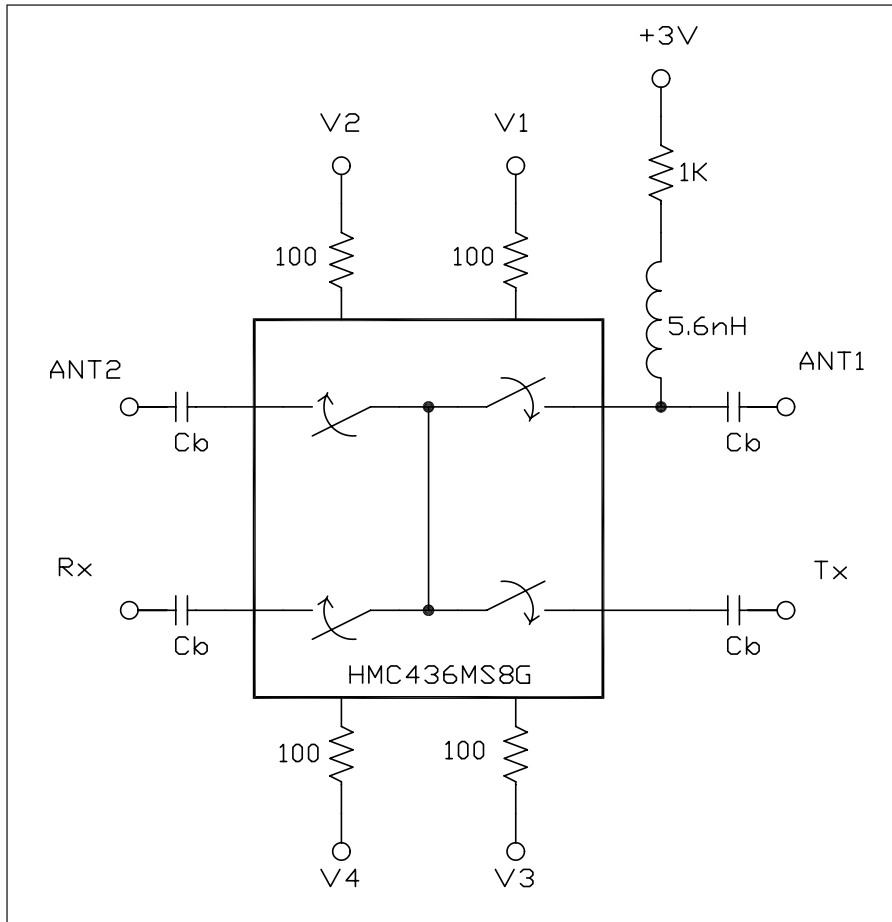

Figure 2 - Application Circuit

Switch Path	V1	V2	V3	V4	State
ANT1 - Tx	High	Low	High	Low	1
ANT1 - Rx	High	Low	Low	High	2
ANT2 - Tx	Low	High	High	Low	3
ANT@ - Rx	Low	High	Low	High	4
All Off	Low	Low	Low	Low	5

Table 2 - Modified Truth Table

SIMPLE BIAS CIRCUIT CREATES ALL-OFF STATE FOR HMC436MS8G

Isolation Performance

The isolation plots for the switch are shown in Figure 3. For reference, the original isolation performance for these paths is also shown. The new all-off isolation state provides between 15 and 50-dB isolation depending on application frequency.

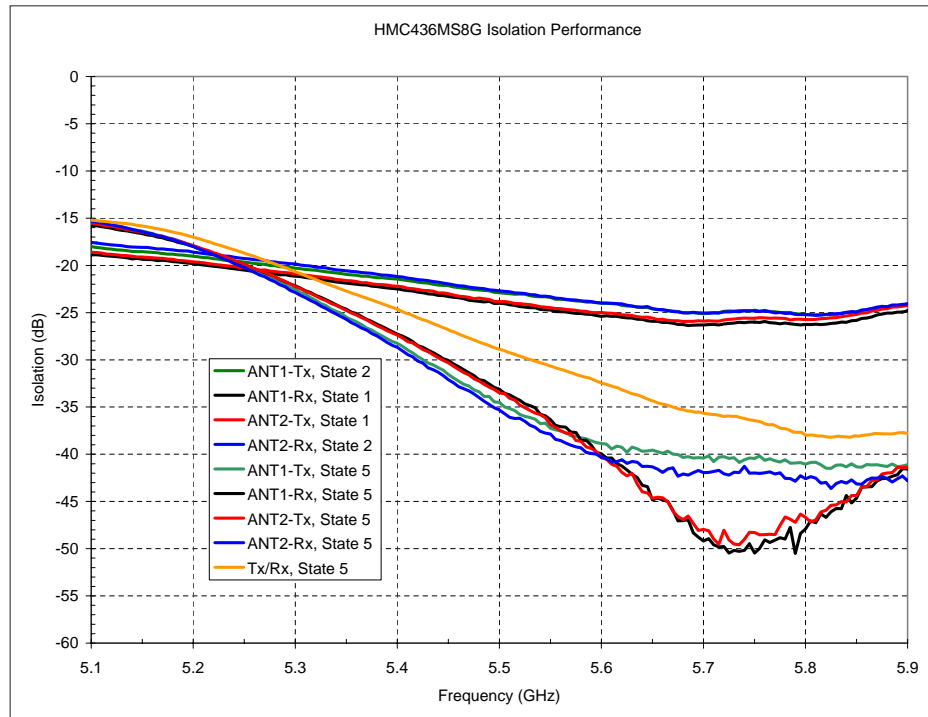

Figure 3 - Isolation Performance

Conclusion

Adding a simple external bias circuit to one of the RF ports on the HMC436MS8G switch will allow the user to simultaneously turn off all of the RF ports.

The resulting isolation performance is greater than 15-dB at the low end of the switch operating frequency to over 40-dB at the high end of the band.

For further information regarding Hittite Microwave Corporation's products, please contact Hittite directly at (978) 250-3343 or visit our website at www.hittite.com

SIMPLE BIAS CIRCUIT CREATES ALL-OFF STATE FOR HMC436MS8G

Notes: